

ALPHANUMERIC CUSTOMER DISPLAY

Stand-Alone FREE/FREE+/BeFREE Module



TECHNICAL OVERVIEW

Description and Application

AlphanumericCustomerDisplay_TO_02.doc

Version 02

November 12, 2009



[TIPRO]

TABLE OF CONTENTS

A. GENERAL INFORMATION	A-1
A.1. Highlights	A-2
A.2. Display Technologies	A-2
B. CONFIGURATIONS AND OPERATING MODES	B-1
B.1. Customer Display as External Tipro Module	B-1
B.2. Customer Display with ESC/PoS Protocol Support	B-2
B.2.1. Via RS232	B-2
B.2.2. Via USB (Virtual COM Port)	B-3
C. ORDERING CODES	C-1

A. GENERAL INFORMATION

The Alphanumeric Customer Display module is a combination of an alphanumeric display and the electronic board which controls the display and communicates to the Computer or Tipro Controller integrated in FREE/FREE+/BeFREE keyboard/touchmonitor/touchcomputer module (see Figure below). Currently, four different LCD displays are available (see chapter A.2), as well as two types of the electronic board.

The first board type (the “**Standard Version**”) is a pure Tipro bus module that connects only to the Tipro Controller. With this one the computer controls the display via Tipro Controller using Tipro run-time software support, i.e. OPoS/JPoS drivers or MIDAPI.

The other board type (the “**ESC/PoS Version**”), besides Tipro bus, provides two additional interfaces: RS232 and USB (as virtual COM port) supporting ESC/PoS protocol. Therefore the display can be operated directly (without Tipro Controller) from computer via either direct cable connection to RS232 computer port or via USB cable.

Physically, the Alphanumeric Customer Display can be manufactured as a free-standing unit (pole affixed to the base) what is a standard offering, or alternatively as a part of a FREE+/BeFREE configuration (pole attached to the rear side of touchmonitor/touchcomputer via special mechanism) what is available for customizations.

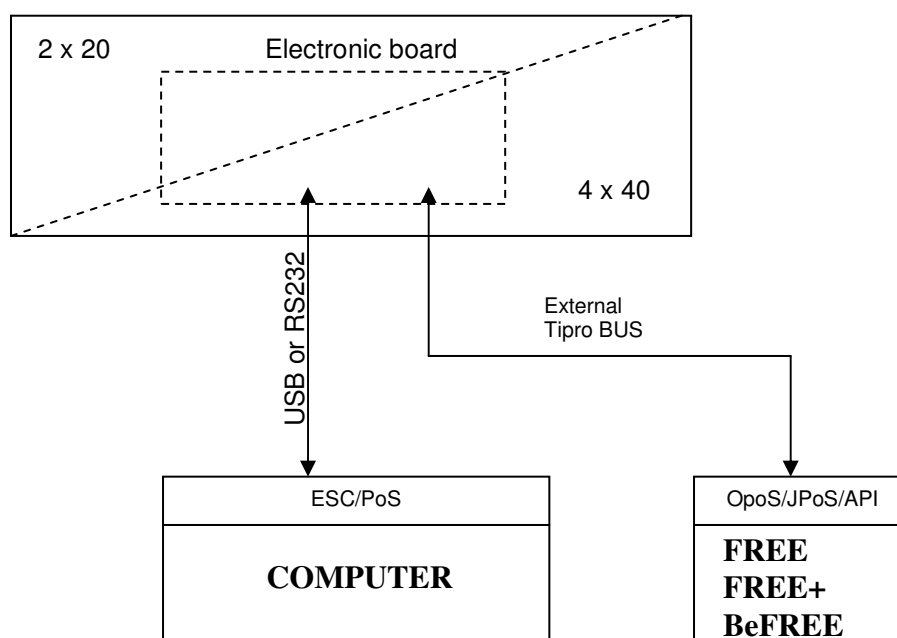

Figure A.1. – Conceptual Connection Diagram

A.1. Highlights

FEATURES

- ◆ Free-standing (stand-alone) display or a part of FREE+/BeFREE configuration
- ◆ Adjustable inclination/tilt (-5° to +15°) and swivel (270°)
- ◆ LCD 2 lines by 20 large font characters (9.6mm) with LED backlight or
- ◆ LCD 4 lines by 40 small font character (4.9mm) with LED backlight
- ◆ Connection: external Tipro bus
- ◆ Optional interfaces for ESC/PoS: RS232 or USB (as virtual COM)
- ◆ Additional +5V power supply might be required (see **Notes 1, 2 and 3** below)

A.2. Display Technologies

Type	Size	Character Size (W × H [mm])	Text Color	Background Color	Backlight
LCD	2×20	6 × 9.6	Dark Gray	Yellow/Green	LED - ARRAY
LCD	2×20	6 × 9.6	White	Blue	LED - EDGE
LCD	4×40	2.8 × 4.9	Dark Gray	Yellow/Green	LED - ARRAY
LCD	4×40	2.8 × 4.9	White	Blue	LED - EDGE

NOTE 1:

In case of External Tipro bus display interface an additional +5V power supply (e.g. TM-VPA) is needed only for Yellow/Green LCDs connected to a FREE/FREE+ configuration with PS/2 + RS232 controller

NOTE 2:

In case of RS232 display interface an additional +5V power supply (e.g. TM-VPA) is always required except when connected to +5V powered RS232 port (5V/500mA at pin 9) of a BeFREE or the host computer

NOTE 3:

In case of USB display interface the additional power supply is not needed for all possible LCD displays, providing that the display is connected to a self-powered or root hub (500mA current rating) and not to a bus-powered hub (100mA current rating)

B. CONFIGURATIONS AND OPERATING MODES

B.1. Customer Display as External Tipro Module

The **standard version** of the electronic board in the customer display is a Tipro module, connected by External Tipro bus cable to the Tipro controller built into a FREE keyboard, FREE+ touchmonitor or BeFREE touchcomputer. Depending on the version of Tipro controller, the display can be operated either via USB or RS232 interface.

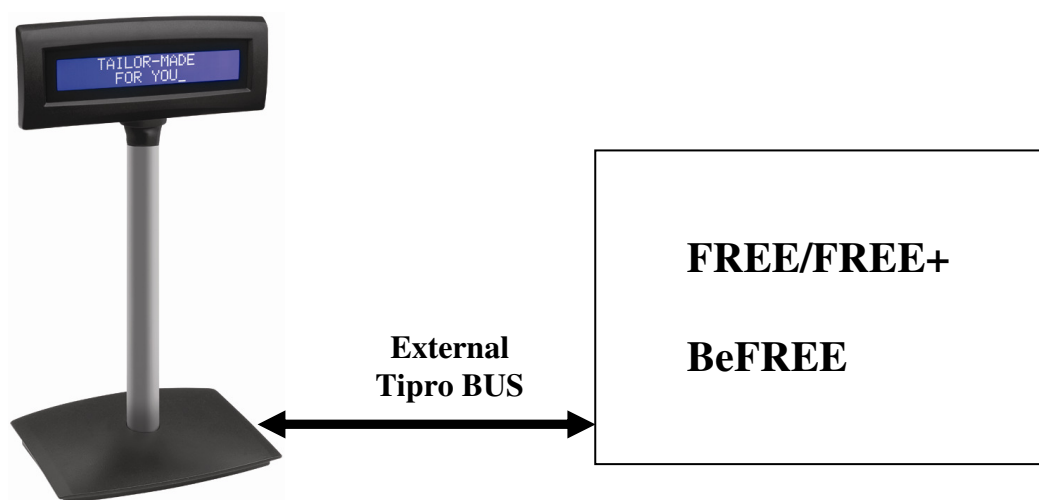

Figure B.1. - Alphanumeric Customer Display with External Tipro bus interface

Ordering codes example: **TM-ZBE-50-C15**
 External Tipro bus cable included

In this configuration the application software controls the display using Tipro OPoS/JPoS drivers or MIDAPI.

B.2. Customer Display with ESC/PoS Protocol Support

The **ESC/PoS version** of the electronic board is a pure superset of the **standard version**. Therefore, besides all of the features described in the previous chapter, it is also capable of executing ESC/PoS commands received directly from the computer either via RS232 interface (variant **R**) or USB as virtual COM port (variant **U**).

B.2.1. Via RS232

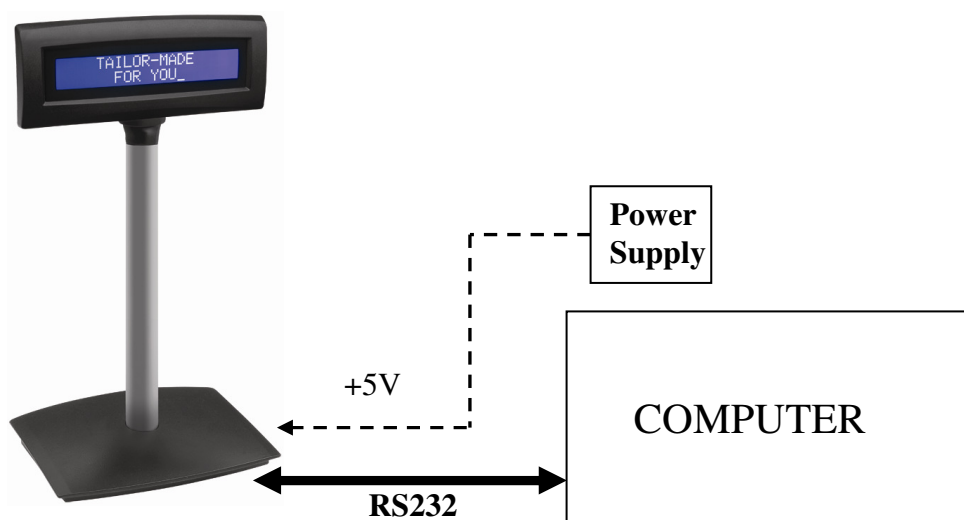

Figure B.2. – Alphanumeric Customer Display with RS232 interface

Ordering codes example: TM-ZB**R**-50-C15
 "RS232 + 5V" cable (TM-CTA) included *
 TM-VPA (power supply) *

* In case when the computer provides powered RS232 port (+5V/500mA at pin 9) the additional power supply TM-VPA is not needed and the cable TM-CTA (D-SUB9 + Power Socket) is replaced by TM-CGA (D-SUB9 with 5V at pin 9)

In this configuration the application software controls the display using ESC/PoS protocol via RS232.

B.2.2. Via USB (Virtual COM Port)

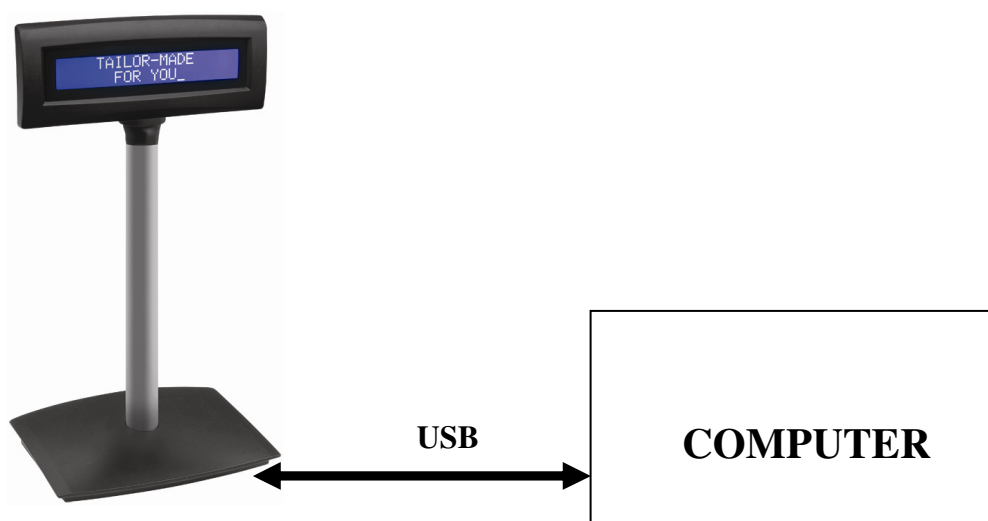

Figure B.3. - Alphanumeric Customer Display with USB (Virtual COM) interface

Ordering codes example: **TM-ZBU-50-C15**
 USB cable (TM-CU1) included *

* The display needs to be connected to a self-powered or root hub with 500mA current rating.

In this configuration the application software controls the display using ESC/PoS protocol via virtual RS232 port.

NOTE:

A virtual COM port is not a 100% compatible replacement of a “real” COM port, as it is physically USB. With virtual COM, after USB interface being logically reconnected (e.g. device reset, USB-cable hot-plugged, power supply interrupted, ...), the virtual COM port must be logically reconnected since the relevant driver has been reloaded.

A virtual COM port probably will not work satisfactory in SW applications that were originally designed with a real COM port in mind. After USB being reconnected, such applications may lose COM functionality or even block in the next attempt to communicate. Therefore, we can recommend the virtual port only for an SW application that was designed considering the USB complexity. Such application should be able to detect the USB reconnect event, and logically disconnect/reconnect the virtual COM port afterwards.

C. ORDERING CODES

	1	2	3	4	5	6	7					
T	M	Z	B	E	5	0	C	1	5	x	x	x

1 Module/Device

Z : Alphanumeric Customer Display

2 Display Technology

L : LCD 2×20 Large fonts, Yellow/Green

B : LCD 2×20 Large fonts, Blue/White

Q : LCD 4×40 Small fonts, Yellow/Green

M : LCD 4×40 Small fonts, Blue/White

3 Display Interface

E : External Tipro Bus (only for TableTop variants)

U : USB (ESC/PoS via Virtual COM Port)

R : RS232 (ESC/PoS)

4 Mounting Style (Integration)

5 : TableTop (with the base) – also referred to as Stand-Alone

5 Reserved

0 Reserved

6 Colour

C15 : black is the standard colour (others available upon request)

7 Custom version (optional)

Three-digit number reserved for product customizations. It is omitted in case of standard version.